



FEATURES

- 2X4 RJ45 with internal magnetics
- Suitable for CAT 5 & 6 Fast Ethernet Cable or better UTP
- Internal magnetics are 100% electrically tested for HI-POT and functionality
- 350 μH minimum OCL with 8 mA bias current
- Recognized by UL 60950-1



ELECTRICAL SPECIFICATIONS @25°C -Operating temperature 0°C TO 70°C										
Part Number	Turns Ratio		Insertion Loss (dB MAX)	Return Loss (dB MIN) 100Ω±15Ω				Crosstalk (dB MIN)	Common Mode Rejection (dB MIN)	Hipot (Vrms)
	TX	RX		1-100MHz	1-30 MHz	30-60 MHz	60-80 MHz			
74F-4010GYD	1CT:1CT	1CT:1CT	-1.0	-18	-14	-14	-10	-30	-30	1500

Mechanicals:

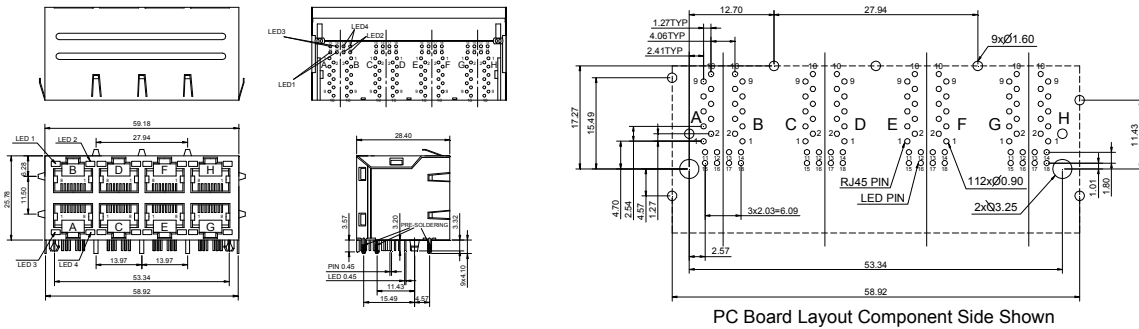

Schematics:

